

Morgan turbine glands (for water turbines)

1. Introduction

Since the end of World War II, the chronic requirement for power and yet more power has become a problem of international rather than purely national interest.

Throughout the world, the increasing tempo of industrialization and the general improvements in living standards have created a situation that can only be countered by bold, far-sighted planning and adventurous engineering. Hence, the now-familiar emphasis on nuclear power stations and hydro-electric schemes. Carbon and its numerous applications in nuclear engineering will no doubt be a subject in some future edition of this publication. This article is concerned with the part carbon-graphitic glands play in the running of that essential to a nation's industrial and domestic power needs - the hydro-electric power station.

To date, nobody has discovered, produced or invented a material for turbine glands that can better carbon. For this reason, carbon is widely employed in this capacity, except in one or two countries like Italy and the U.S.A. where soft packing glands are preferred. Carbon glands are reliable. can be easily fitted in comparison to other types. do not need frequent adjustments. and, very important, do not damage or wear the turbine shaft.

The glands manufactured by Morganite Carbon Limited are highly-specialized products developed in association and collaboration with prominent turbine constructors throughout the world. They have won for the Company a substantial percentage of the world's markets for such equipment.

So far, glands have been supplied for shaft diameters up to 1170 mm. It is hoped, however, that the Company will shortly embark upon a contract for the largest. Most ambitious hydro-electric scheme in the world, where shafts of 1350 mm diameter will have to be sealed.

Every water turbine installation, big or small, introduces its own peculiarities, its own difficulties and running conditions. This article can do little more than cover the subject in general terms and, in doing so, signpost the broad principles and rulings that dictate which gland materials and gland design are best suited to a specific application.

2. Kaplan and Francis water turbines

To those concerned with scaling, there are two basic patterns of water turbine - the Kaplan and the Francis. (There is also, of course, the Pelton wheel-which is considerably used under very high head conditions - but since machines of this type present no sealing problems they fall outside the scope of this article.)

The Kaplan, which consists of a variable pitch propeller that can be adjusted to suit the load, is the *more* efficient of the two and is used mostly where there is a likelihood of a wide load range.

The Francis is a reaction turbine, in which the water flows radially inwards through guide vanes into the runner and,

after imparting the thrust, leaves axially. It is usually adopted for schemes where the pressure head is high, say, 600 metres.

Both these types of turbine differ substantially in their running conditions and it is quite unlikely that a gland designed for one could be successfully employed with the other.

In Kaplan installations, for example, a gland must work effectively under high pressure, whilst in Francis applications it must be capable of sealing a vacuum during running, but a pressure when the turbine is stationary. Furthermore, Kaplan turbines are normally sited where the water flow fluctuates and the variable pitch facility can be utilized most advantageously, whilst Francis turbines having fixed blades, are retraced to schemes where a supply of water at a reasonably constant pressure can be anticipated.

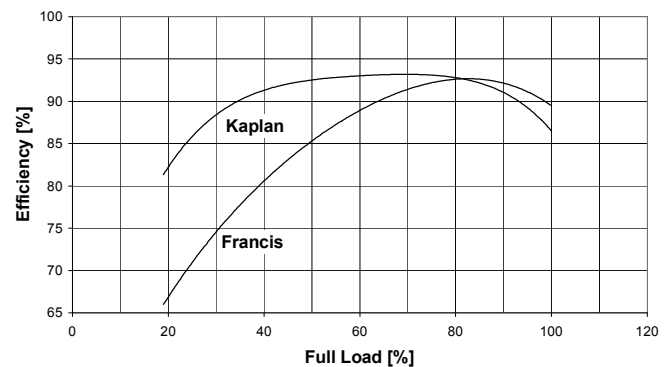

Fig. 1 Typical efficiency curves for Kaplan and Francis turbines

As might be expected, each type of installation introduces a specific crop of problems for the gland manufacturer. If maximum efficiency is to be obtained from any gland it is important that every operating circumstance is understood and fully evaluated before a gland is designed and put into service.

In the following paragraphs, an attempt will be made to show the relationship between different types of gland, various gland arrangements and the two classes of turbine.

3. Gland types

Although it is not uncommon for gland makers to produce completely 'unitized' gland assemblies, the Company's experience indicates that this is a rather expensive practice, since defects or gland malfunctioning obviously necessitates the removal and replacement of the entire assembly. Instead, Morganite Carbon Limited provides the gland rings only, the housing and gland faces being manufactured by the turbine constructor in close liaison with the Company.

The majority of gland rings supplied conform broadly to either one of two patterns – the tenon - type or the wedge - type. Depending upon the vagaries of the particular commitment, rings of the same type may differ in detail amongst themselves, although in an overall sense, they will generally comply with the ensuing descriptions.

3.1 Tenon-type

This gland consists of a ring composed of a number of carbon segments held together by a peripheral close-coiled tension or garter spring. It earns its name from the method of assembling the carbon segments, each of which is connected to its neighbour by an integral tongue fitting into a recess.

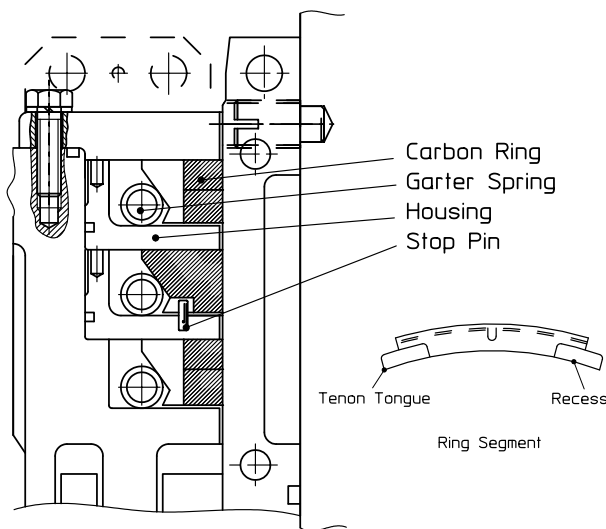

Fig. 2 Tenon-type gland

Glands of this type are self-adjusting in that the segments move radially inwards under the force of the spring as wear takes place. The tongues and recesses must, of course, be machined with sufficient allowance to permit this radial closing to occur without buckling or distorting the ring. To prevent the ring turning with the turbine shaft, each segment is located radially with respect to the housing by a pin.

Since the gland must seal both the shaft circumference and the radial housing face, the outside circumference of the ring, where the spring seats, is machined to a tapered form. Thus, the inward load of the spring has two components: one urging the segments towards the shaft and the other pressing the segment faces into contact with the radial face of the housing.

To provide added protection against axial leakage, tenon rings are usually installed in pairs with the tenon joints between the upper and lower rings staggered so that there is no direct passage for the water. This arrangement is employed with both the single tenon type already described, and the double tenon ring, which is a similar but stronger version of the gland having tenons and recesses at both ends of each segment.

Although tenon rings are by far the most common, they are not recommended for shaft diameters above 500 mm

and water pressures greater than 2 bar. At figures much in excess of these certain disadvantages soon become evident:

- Since it is neither practicable nor economic to make tenon rings in a very wear-resistant grade, there may be pronounced wear at higher water pressures.
- Frequently, there is a high rate of leakage through the inevitable gaps at the tenon joints.
- As a result of that, the tongues are subject to water erosion.
- Carbon being a relatively brittle material, the tongues are always prone to fracture, particularly during installation.

3.2 Wedge-type

To overcome as many of these disadvantages as possible, another type of ring has been evolved in which the tenons are replaced by wedges. This ring – appropriately designated the wedge-type - has won an immense popularity and is likely to supersede the tenon ring in the majority of installations.

Like the tenon-type, this ring is made up of carbon segments, the actual quantity of which will vary from eight to sixteen depending upon the shaft diameter. Instead of having tongues and recesses, the ends of these segments are chamfered to present sliding surfaces to tapered wedge pieces, one of which is interposed between the ends of every pair of neighbouring segments. A garter spring seated in a groove around the outside circumference of the ring holds the assembly of segments and wedges together. Pins rooted in the outer sealing faces of the gland housing and located in slots in the segments stop the gland from turning with the shaft.

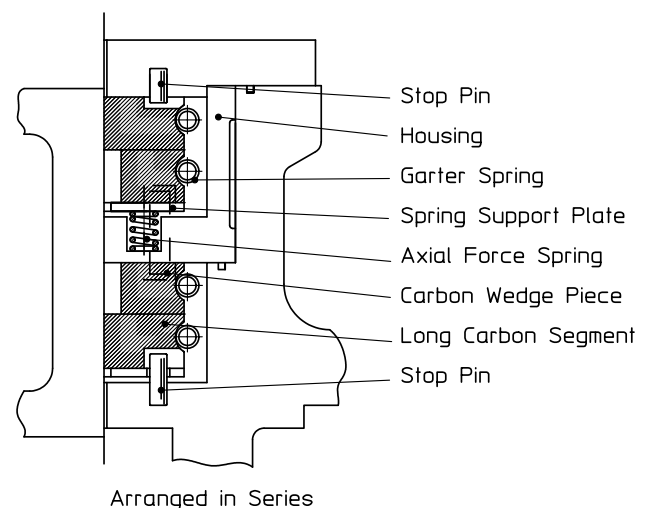

Fig. 3 Wedge-type gland rings

Wear on the carbon is taken up by the action of the spring continually forcing the segments into contact with the shaft, this inward movement of the segments being accompanied by a corresponding outward shifting of the wedges. Thus, at all times under all conditions of wear, the

gland presents a true and pressurized surface to the shaft circumference.

One of the main differences between the tenon and wedge rings is the inability of the latter to seal in the axial direction of its own accord. Obviously, if the self-adjusting capabilities are to be obtained, it is not feasible to have the spring bearing against a tapered peripheral face as it does in the tenon ring. Separate provision must be made therefore to attain adequate axial sealing.

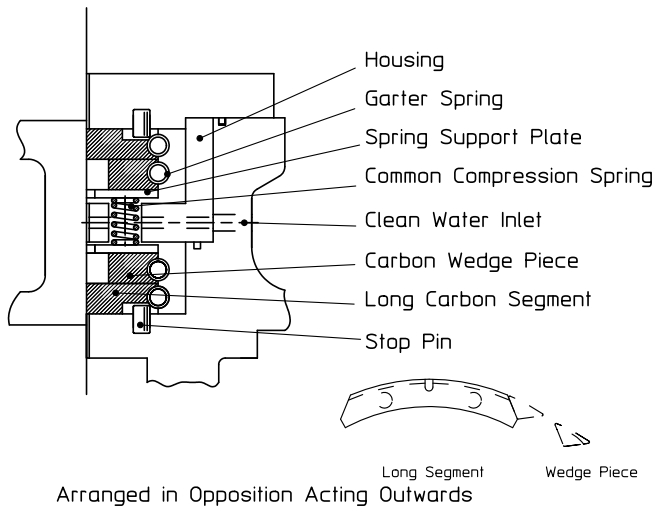

Fig. 4 Wedge-type gland rings

This is usually achieved by separate compression springs housed in recesses in the gland housing and urging in the axial direction on metal support plates bearing against one face of the gland ring. Normally, two springs are applied to each segment.

Further safeguard against axial leakage is provided by mounting two rings one above the other in much the same way as with the tenon-type, the joints between segments being arranged out of coincidence.

Developed in association with a leading turbine maker, wedge-type gland rings offer very distinct advantages over their tenon-type counterparts.

- They are more efficient.
- The leakage rate is only about one-fifth of that of the other gland.
- Being much simpler in shape they can be produced in carbon materials that are more wear resistant and more suitable for higher pressures (up to 3.5 bar).
- They are far less prone to damage.

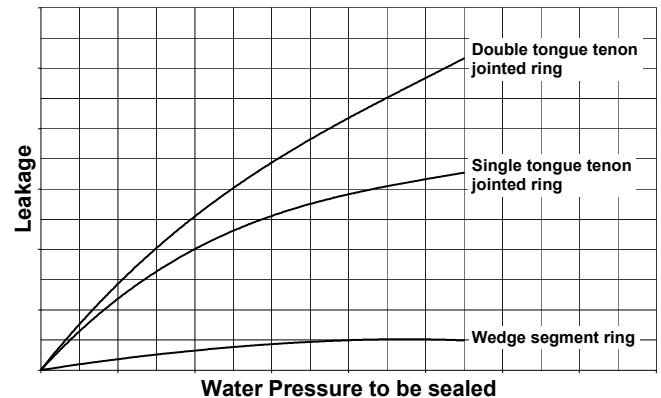

Fig. 5 Typical curves for leakage and pressure for different gland types

Already, wedge-type carbon rings absorb a substantial proportion of current business in water turbine glands. There is every prospect that their considerable appeal will bring about a general re-appraisal of turbine sealing practices and techniques.

4. Counterfaces and housings

These are normally made by the turbine manufacturer to suit the gland ring supplied, although the Company will almost invariably collaborate to help resolve details of design and materials.

The housings are generally manufactured in one of the cast irons and are radially grooved to accommodate the gland rings. Reamed holes are provided for the stop pins and, if the gland is of the wedge-type, holes are cut to house the axial springs.

When two or more housings are fitted, they are located together by dowel pins.

The gland's bearing faces - both axial and circumferential - may be of phosphor-bronze, stainless steel or cast iron. The circumferential surface is normally provided by a sleeve on the turbine shaft and the axial counterface by either a separate plate closing one end of the housing or a machined face on the housing itself.

5. Materials

One of the major problems in manufacturing glands for sealing water turbines is that of obtaining experimental data on the performance and characteristics of new carbon grades. The only real test comes during service, but, although constructors are very willing to cooperate, they naturally enough do not want to run the risk of damaging an expensive shaft purely for the purpose of developing a better gland material. Further, test rigs that simulate anything approaching genuine operational conditions are a virtual impossibility.

Thus, by necessity, the grades commonly used for glands are those that have been proved and well-tested in other applications; they are those, too, that can ensure a gland life and reliability for a length of time similar to that of the normal turbine overhaul period.

All the suitable carbon gland materials stem from one basic carbon-graphite grade- LINK CY2, a tried and trusted grade of close grain and reasonable hardness and strength. One of its outstanding merits lies in the fact that, unlike many carbon materials, it can be produced in large component sizes.

To improve its wearing properties and add strength and hardness, LINK CY2 is sometimes impregnated with one or other of the resins, in which case its designation becomes either LINK CY2WA or LINK CY2C, depending upon the particular resin incorporated. Grades of this class are used mostly in wedge-type glands.

Tenon rings are frequently made from LINK CY2T, which is a wax-impregnated grade. In comparison with other grades, this material has superior self-lubricating characteristics. Electro-graphites, natural graphites and the metallized carbons seldom give satisfactory service on gland materials. The first two are not strong or hard enough to withstand the unusually arduous operational conditions and the metallic grades tend to accelerate wear on the turbine shaft.

6. Methods of installation

Glands can be installed in any one of a number of ways. The actual method to be employed in any one case will, of course, depend upon the circumstances of that particular application and a correct appreciation and interpretation of certain factors. Since it is neither useful nor practicable to describe the many detail variations in gland disposition and installation, this section is confined to generalized comment on the main methods of fitting glands to seal effectively under different conditions of operation. As remarked earlier, glands are installed in pairs to provide efficient axial sealing, two such pairs being normally fitted to each turbine shaft. When the water in the turbine is clean, these pairs are arranged in series, i.e. both facing the same way (Fig. 3). Unfortunately, this is a near ideal instance, since the water providing the power is, in fact, seldom clean. Indeed, if the plant is sited for tidal operation, there is every possibility that the sea water will contain a considerable amount of sand, a substance which will wear the glands to the point of non-effectiveness very rapidly indeed.

Hence, in the majority of installations an alternative disposition must be utilized. In one method, the gland

pairs are mounted in opposition to each other and clean water is pumped through a connexion into the space between them (Fig. 4). This water, which must be at a higher pressure than the turbine water, gives a positive pressure in the sealing space and thus augments the influence of the glands. This is probably one of the most effectual ways of keeping turbine water out of the glands and gland housings. It can be adopted with both wedge-type and tenon-type rings, although the latter, having a higher leakage rate, need more water pumped between them.

The main drawback is the provision of a sufficient quantity of clean water at the right pressure. This usually necessitates the added complication of a separate fluid circuit with filters, stop valves and water pumps.

When it is not possible, practicable or economic to supply high pressure clean water, grease is sometimes pumped into the gland space. This has almost exactly the same result as high pressure water sealing, but is rather more liable to produce running troubles. Any sand or grit, for example, entering the gland space is soon picked up by the grease, which quickly takes on the character of a particularly coarse abrasive paste. Grease, too, will dry out and harden in time and this will eventually cause jamming. Although some form of gland space sealing is desirable on most turbines, it is virtually essential on those established in estuaries and on coastal locations for tidal operation. At these sites, the water conditions are extreme; dirt, grit and sand are constantly held in suspension, and even shellfish may be a hazard to the gland rings. Sometimes, additional protection can be obtained by installing a radial face seal, but this course is usually restricted to vertical turbines working at a very low pressure head. On horizontal machines, the weight of the seal will tend to pull it out of alignment, whilst too high a pressure head will impose a prohibitive, possibly destructive, load on the carbon. Frequently, therefore, high pressure water sealing alone must suffice

The question of keeping dirty turbine water from the glands is a problem largely associated with Kaplan turbines, where the rings are under pressure all the time the turbines are running. On machines of the Francis-type, the glands must perform a double function; they must seal a pressure when the turbine is stationary but a vacuum when it is driving.

Failure to seal this vacuum results in air entering the runner, where it causes cavitation and leads to poor turbine characteristics. Carbon glands are quite capable of preventing the ingress of any great amount of air, but they must be supplied with water, since dry-running carbon will quickly wear under the severe prevailing conditions. Once again, therefore, clean water must be pumped into the gland space. Not only does this increase the efficiency of the air sealing but it also reduces the infiltration of turbine water when the machine is shut down.

Another arrangement occasionally employed in Francis turbines is the composite carbon gland. This consists of a plain carbon ring surrounded at its periphery by a larger carbon ring, the joints between segments being staggered out of coincidence. Feed water is pumped into the gland space through holes in the inner ring, and slots are cut in

the segments of both rings to provide location for the gland stop pins.

7. Conclusion

There is no known material that has proved to be superior to carbon for turbine glands. This, allied to the increasing popularity of highly-specialized seals like the wedge-type and the diversity of arrangements possible with carbon rings, promises a continued utilization of carbon glands throughout the world..

Nevertheless, in common with most sealing equipment, no existing carbon gland can completely satisfy the circumstances of all applications and all conditions of operation. Thus, every installation must still be appraised on its individual merits and the gland type, material grade and method of arrangement selected accordingly.

The extent by which this situation will change in the coming years is almost entirely governed by the degree of practical experimentation that can be carried out. This requires close collaboration with the turbine constructors, since realistic test rigs are an impossibility and useful investigation and evaluation of new rings and new materials can only be obtained by using turbines that are in service. Happily, there is a history of amicable liaison between the Company and the turbine manufacturers, who have given every possible assistance in the past and who will undoubtedly be willing to co-operate as far as they can in the development of more versatile glands and more comprehensive carbon grades in the future.