



# Industrial Brush Guide

MorganAM&T



# How To Order National Carbon Brushes

## **Morgan AM&T**

251 Forrester Drive  
Greenville, SC 29607  
Customer Service: 1-800-543-6322  
General: 1-864-458-7777  
Fax: 1-864-281-0180

## **Morgan AM&T**

2901 Second Ave. South, Ste. 140  
Birmingham, AL 35233  
Customer Service: 1-800-858-3366  
General: 1-205-251-4000  
Fax: 1-205-252-6300

See Brush Specification Form on page 17.

- Step 1. If available, provide the following information:
1. Original equipment part number
  2. Motor name plate data
  3. Commutator or slip ring
  4. Present brush grade - usually stamped on the back face of the brush
  5. Past or present performance problems
- Step 2. Specify the dimensions of the brush in the sequence: thickness x width x length. See page 6 for more details. The brush is always a few thousandths smaller than the nominal fractional or metric dimension, according to NEMA tolerances. Best results are obtained with calipers, micrometers rather than a scale or ruler.
- Step 3. Turn to the Brush Styles section of this manual and identify the style number which matches the brush you wish to order.
- Step 4. If you were unable to find the correct brush style in Step 3, our customer service personnel will be able to assist you in specifying the correct design.
- Step 5. Specify the required shaping and machine work as illustrated on page 7.
- Step 6. Specify whether the shunt connection is a Type Q or Type R. See page 8.
- Step 7. Determine the required length of the shunt(s) as illustrated on page 9.
- Step 8. Specify if the shunt is protected by means of flexible insulation or tin plating.
- Step 9. If a PAD is required, refer to Figure 16 on page 9 for instructions.
- Step 10. If a clip is required, refer to Figure 17 on page 10 for instructions.
- Step 11. To specify a terminal, refer to Figures 18 and 19 on page 10.

**Note:** While reading this entire manual is not necessary for ordering National Carbon Brushes, we believe that a review of its contents would provide beneficial insight to carbon brush designs. If you have any questions, please call or write.

# Brush Styles

# Single Wafer With One Shunt

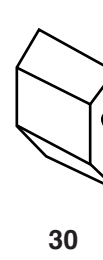
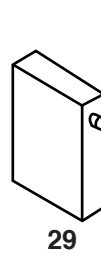
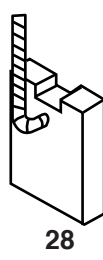
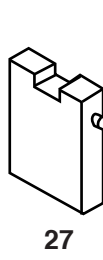
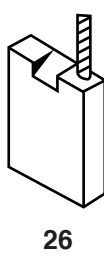
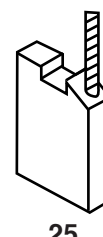
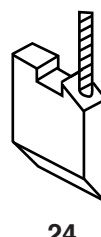
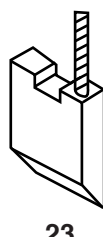
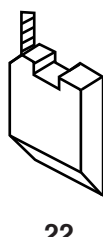
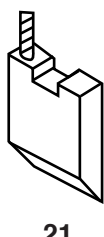
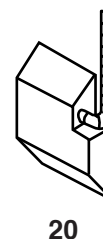
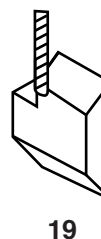
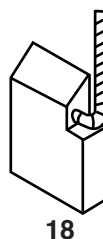
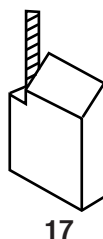
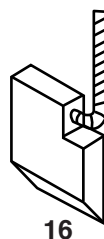
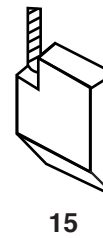
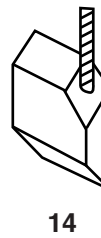
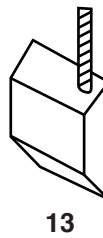
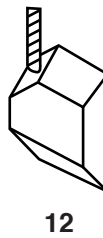
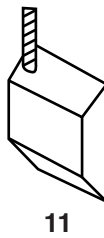
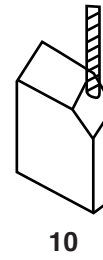
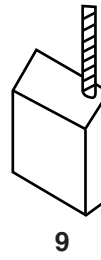
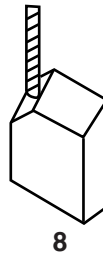
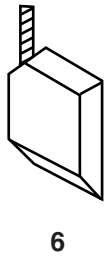
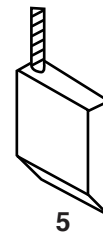
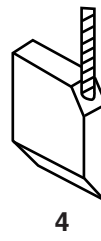
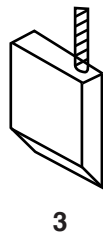
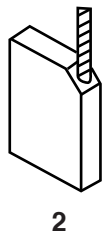
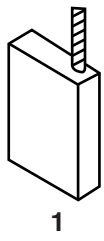

# Single Wafer With One Shunt

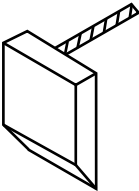

31

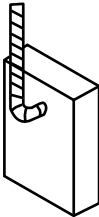

32

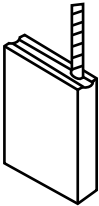

33

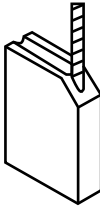

34

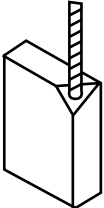

36



37

# Single Wafer With Multiple Shunts

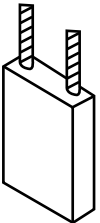

38

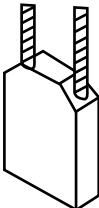

39

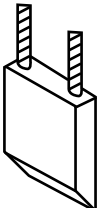

40

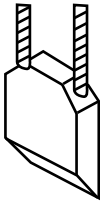

41

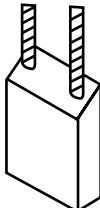

42

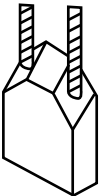

43

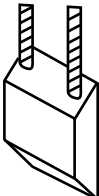

44

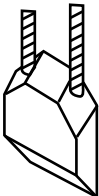

45

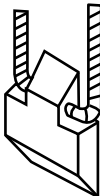

46

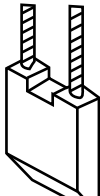

47

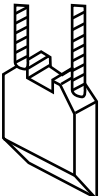

48

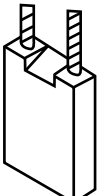

49

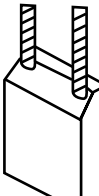

50

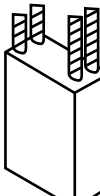

51

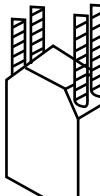

52

# Multiple Wafers with One Shunt Per Wafer

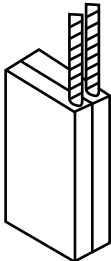

53

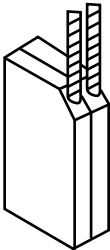

54

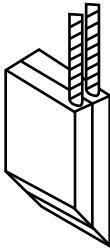

55

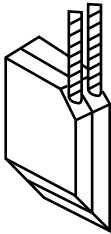

56

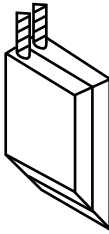

57

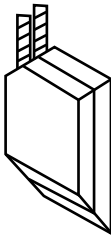

58

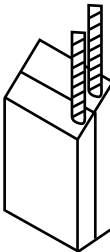

59

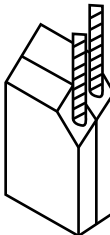

60

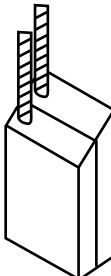

61

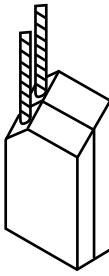

62

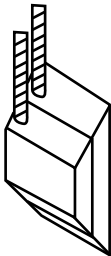

63

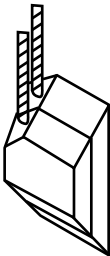

64

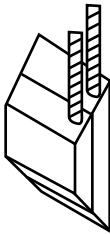

65

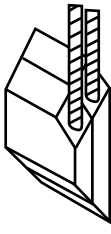

66

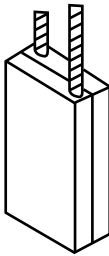

67

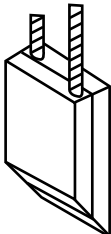

68

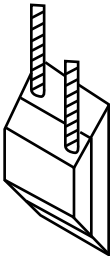

69

# Multiple Wafers With Multiple Shunts Per Wafer

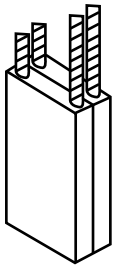

70

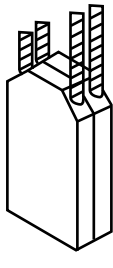

71

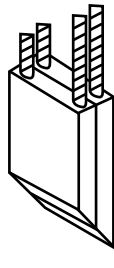

72

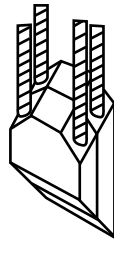

73

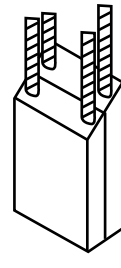

74

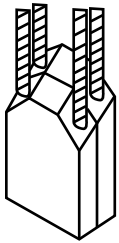

75

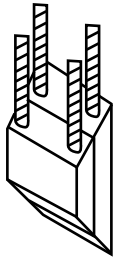

76

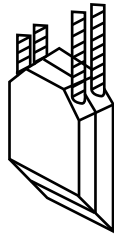

77

# Slip Ring Brushes

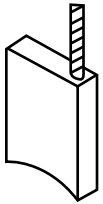

78

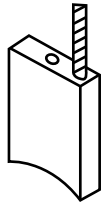

78A

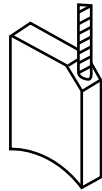

79

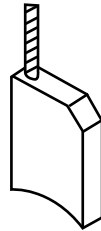

80

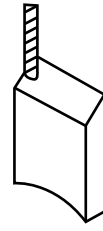

81

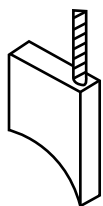

82

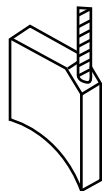

83

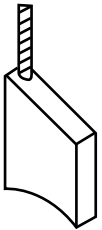

84

# Special Brush Styles

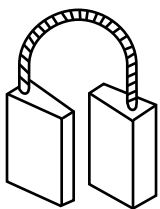

85

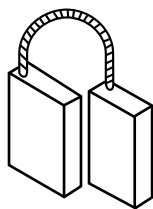

86

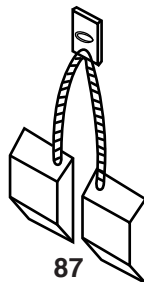

87

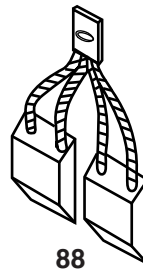

88

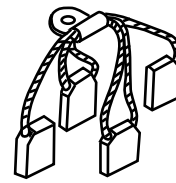

89

# Common Brush Constructions

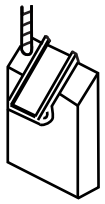

90



91

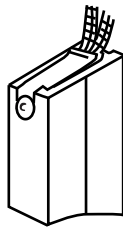

92

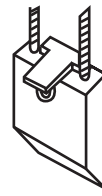

93

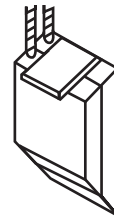

94

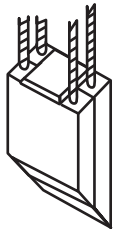

95

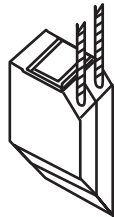

96

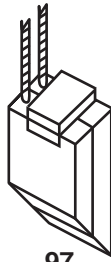

97

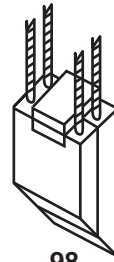

98

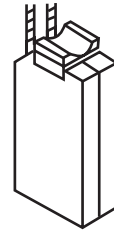

99

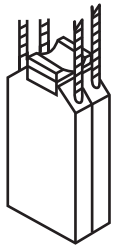

100

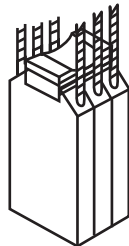

101

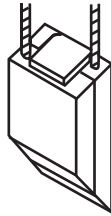

102

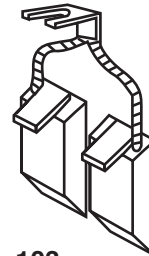

103



104

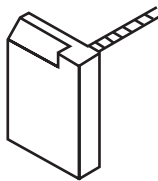

105

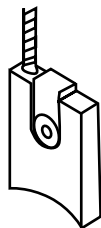

106

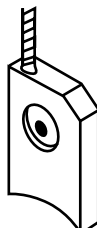

107

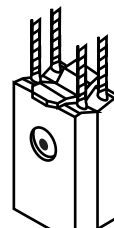

108

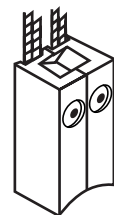

109

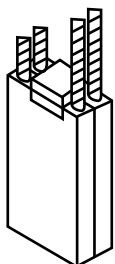

110

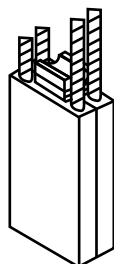

111

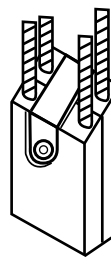

112

# Dimensions

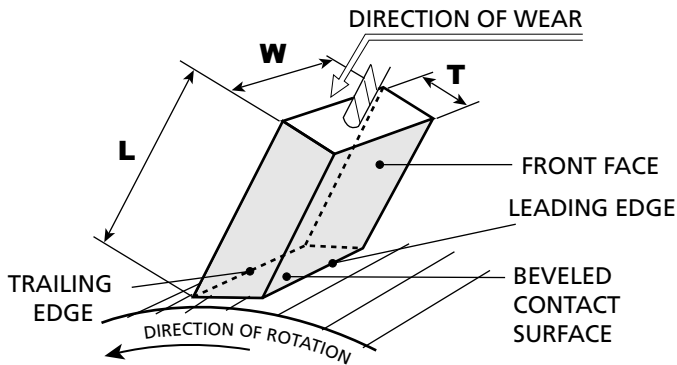

Figure 1. Commutator Brush

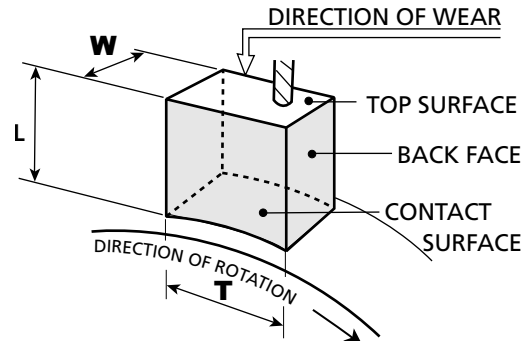

Figure 2. Slip Ring Brush

**T = Thickness** The dimension tangent to the circumference of the collector surface. Generally this dimension is smaller than the width for commutator brushes and larger than the width for slip ring brushes.

**W = Width** The dimension which lies parallel to the axis of the collector.

**L = Length** The dimension which is reduced by wear of the brush. When specifying, measure the maximum overall dimension of the carbon only.

Refer to Figures 1 and 2.

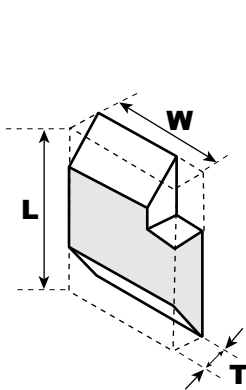

Figure 3.

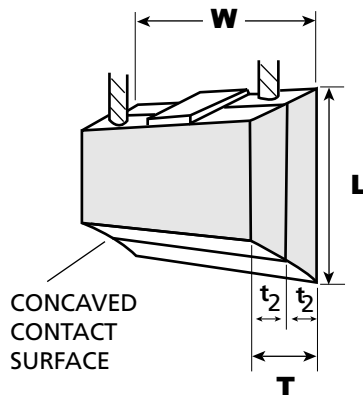

Figure 4. Multi-wafer Brush

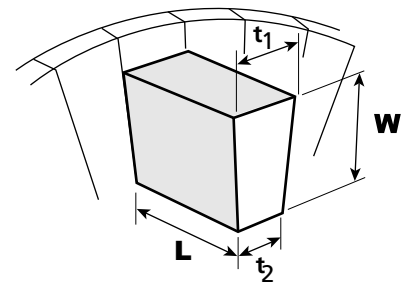

Figure 5. Wedge Brush

Note 1. The size of a brush is defined by the dimensions of the outer edges that will contain the whole brush shape. See Figure 3.

Note 2. The thickness of a multi-wafer brush is the total dimension which enters the brush box. See Figure 4.

Note 3. When dimensioning brushes used on flat collectors, refer to Figure 5.

Note 4. To ensure proper manufacture, it is important to specify dimensions in the sequence:

thickness x width x length  
**T x W x L**

# Shaping

## Bevels

	Top Bevel	Bottom Bevel
<u>Description</u>	Brush top is not at right angles to brush faces	Contact surface is not at right angles to brush faces
<u>Purpose</u>	Provide stability to brush location in the brush box	Applies to brush running in a trailing or leading position
<u>Typical Angles</u>	0° 5° 20° 25° 30° 35° 40°	30° 35° 40° (leading brush) 0° 5° 10° 15° 20° 25° (trailing brush)
<u>To Specify</u>	Use your National Bevel Gauge or the bevel chart on page 11 to determine the angle measurements. If the bevels are parallel, please specify.	

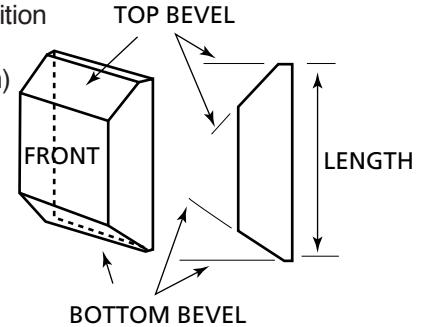

Figure 6. Bevels

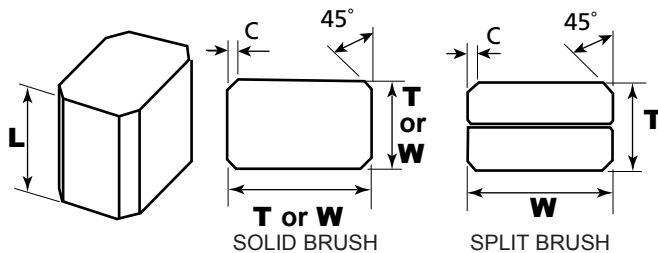

Figure 7. Chamfers

**Chamfers** are obtained by removing material from the side edges of a brush to eliminate the risk of jamming at the internal corners of the brush box. As shown in Figure 7, the standard angle of chamfer is 45 degrees. All National Electrical Carbon brushes are chamfered according to NEMA specifications unless otherwise requested.

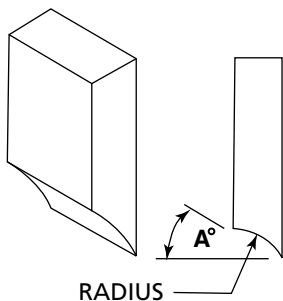

Figure 8. Concaving or Radiusing

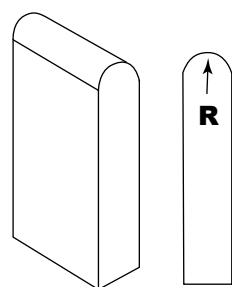

Figure 9. Convexing

It is sometimes necessary to radius the top and/or contact face of a brush. A contact face machined to suit the curvature of the collector is referred to as a **concave**. See Figure 8. The term **convex** top applies to brush tops machined to accommodate certain types of brush holder pressure fingers. See Figure 9. When specifying concave and convex surfaces, state the radius of the required curvature. If the radius is not centered, specify the appropriate bevel angle. See the radius chart on page 11.

**Special machine work** is often required. Figure 10 illustrates several examples.

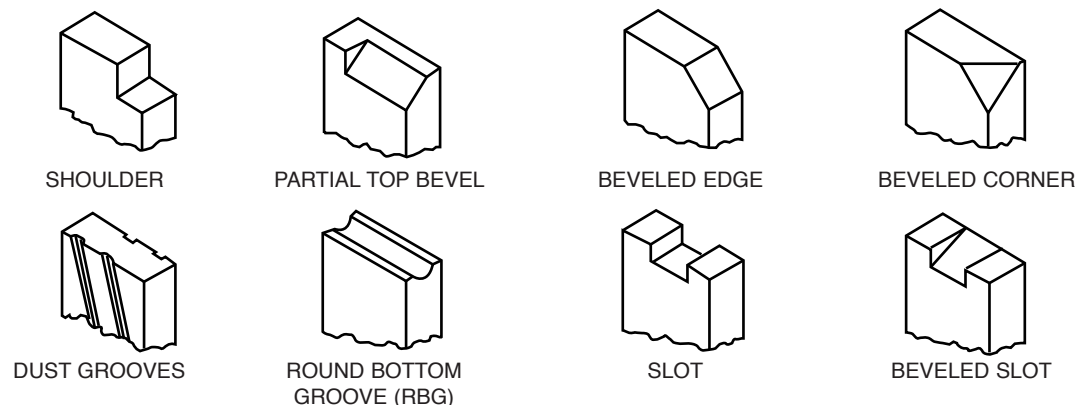

Figure 10

# Shunt Connections

The **tamped** or **type Q** connection is mechanically strong and of low electrical resistance. Patented by Morganite in 1909, the tamped connection has evolved as the preferred means of shunt attachment for most applications. The cross-sectional view in Figure 11 illustrates the basic construction of this connection. The flexible shunt is secured within the brush structure by tamping a conductive powder between it and the wall of the drill hole. This type of connection is designated with the letter "Q".

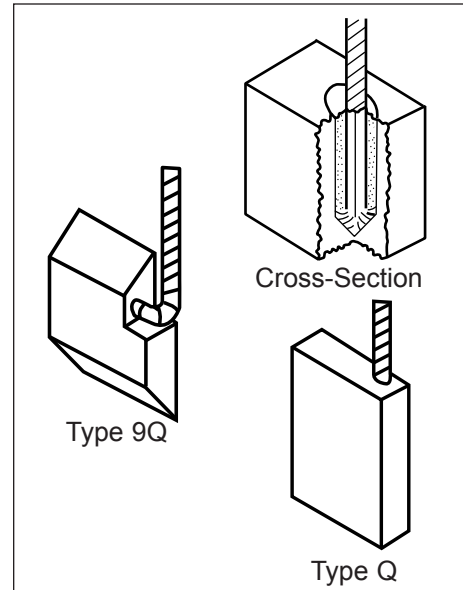

Figure 11. Tamped Connections

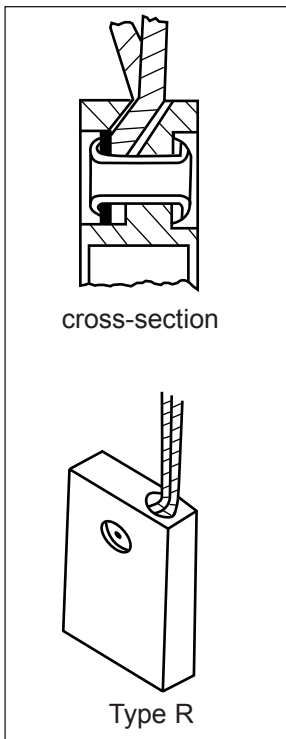

Figure 12. Rivet Connections

The **riveted** or **type R** connection is generally preferred to the tamped connection when heavy vibration is encountered. The cross-sectional view in Figure 12 shows this connection to be constructed of a tubular rivet securing a looped shunt against a counterbore machined in the brush material. This type of connection is designated with the letter "R".

**Shunt locations** by position number are illustrated in Figures 13 and 14. When specifying locations, it is important to orient the brush correctly as follows:

- a. Brushes with top and/or bottom bevels: see Figure 13.
- b. Brushes with a thickness dimension which is greater than the width: see Figure 14. This generally applies to slip ring brushes.
- c. Brushes with a top clip and no top or bottom bevel should be oriented with the clip attachment on the back face. For slip ring brushes the clip attachment should appear on the right side.

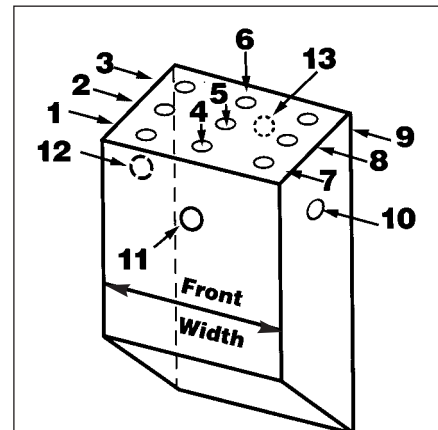

Figure 13. Typical Commutator Brush

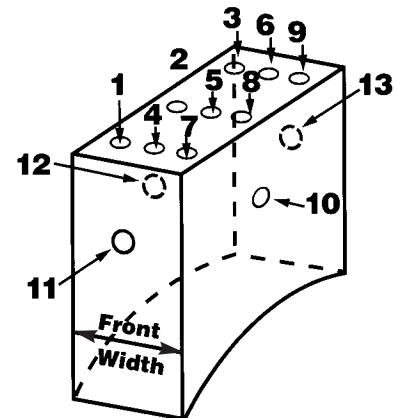

Figure 14. Typical Slip Ring Brush

Shunt Locations

# Shunts

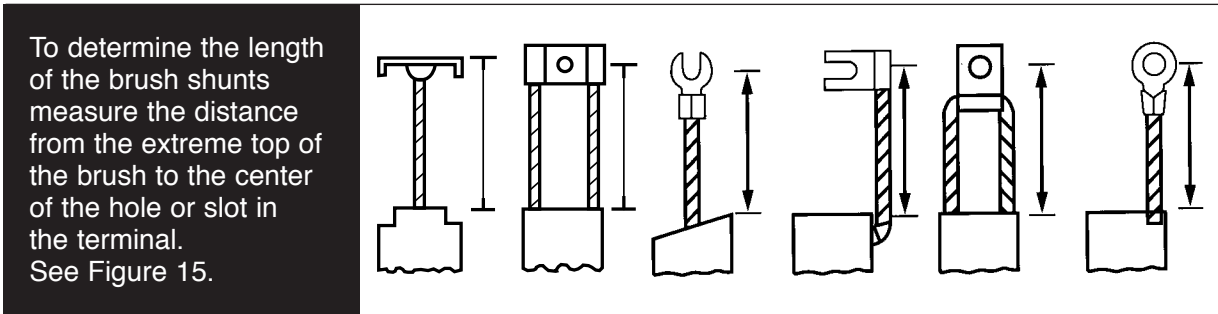

Figure 15. Shunt Length

Flexible shunts are normally left bare to permit maximum flexibility and cooling capacity. Nevertheless, certain machines have their brush gear mounted in a manner that risks the brush shunts grounding on the frame. For these applications flexible insulation would be specified to provide protection. When brushes are used where corrosive gases are present, tin-plated shunts should be specified to provide some measure of protection.

Shunt cable will be sized to match the capacity of the brush grade.

# Pads

<u>Construction</u>	Composite material consisting of a hard top bonded to a resilient bottom and cemented to the brush top.
<u>Functions</u>	<ul style="list-style-type: none"> <li>- Distribute spring pressure uniformly over a multi-wafer brush.</li> <li>- Permit controlled relative movements between wafers of a multi-wafer brush.</li> <li>- Dampen vibration transmitted from the collector surface.</li> <li>- Insulate the brush holder pressure device from the brush top.</li> <li>- Protect against mechanical indentation of the brush top.</li> </ul>
<u>To Specify</u>	Measure the width & length of the Pad and designate the style.

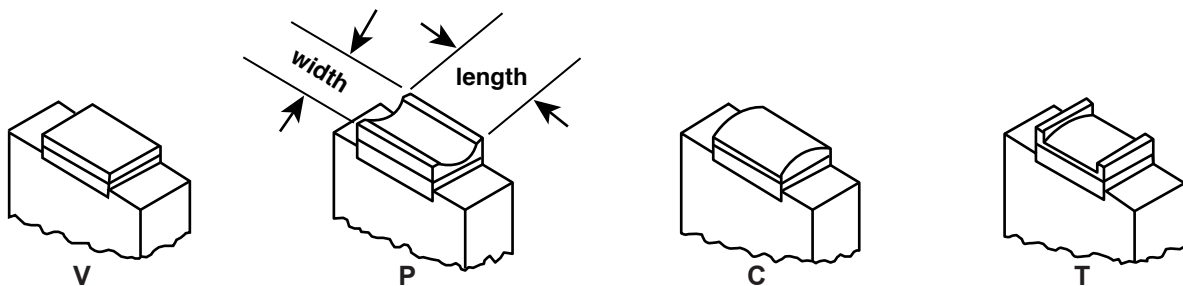

Figure 16. Pad Styles

# Clips

Construction Generally of electro-tin plated cold rolled steel or stainless steel.

- Functions
- Protect against mechanical indentation of the brush top.
  - Locate the pressure finger on the brush top.
  - Provide a bridge over the two or more parts of a multi-wafer brush.
  - Provide a lifting clip for removal from the brush gear.
  - Provide an attachment for shunts.

To Specify Measure the width of the clip and designate the type. If EXTENDED A type, specify the length extended beyond the carbon.

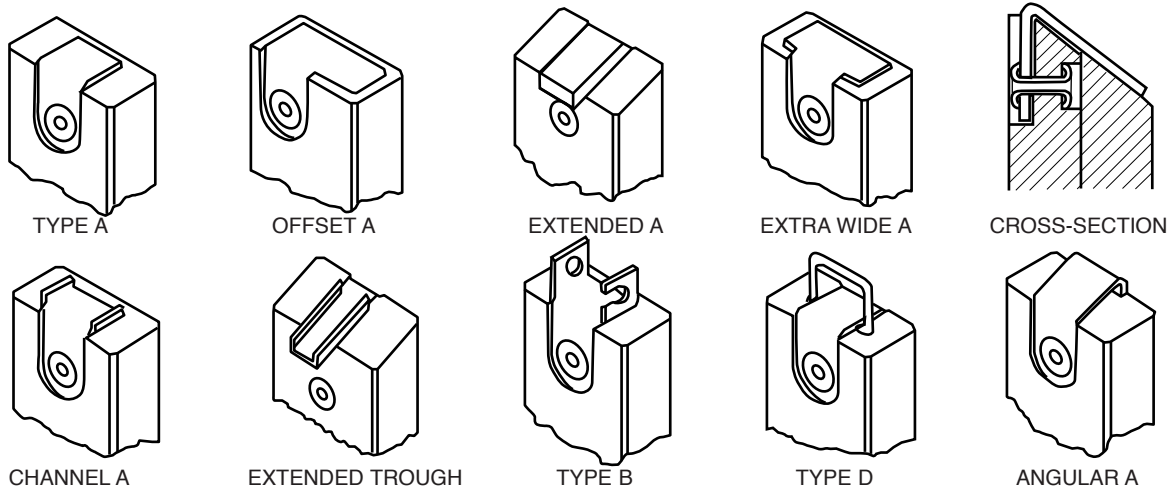
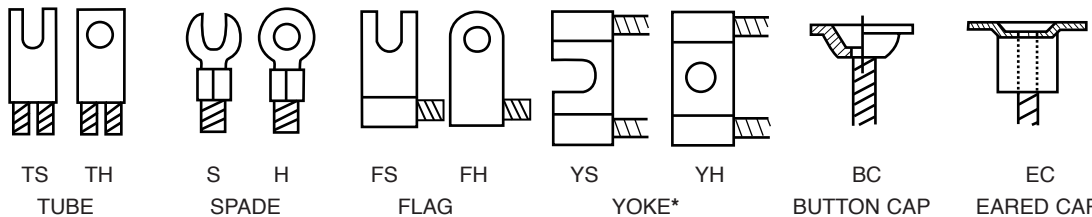

Figure 17. Clips

# Terminals

Figure 18. Terminals



Type  
Description

TS TH S H FS FH YS YH BC EC  
TUBE SPADE FLAG YOKE\* BUTTON CAP EARED CAP

To Specify Indicate the style  
For screw or bolted connections measure the slot width or the hole diameter using Figure 19 and specify in 32nds of an inch.

\* Note: Yoke type terminals are a European standard.  
Unless specifically requested they will be charged to a functionally equivalent tube or spade terminal

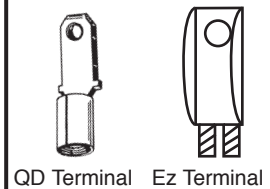
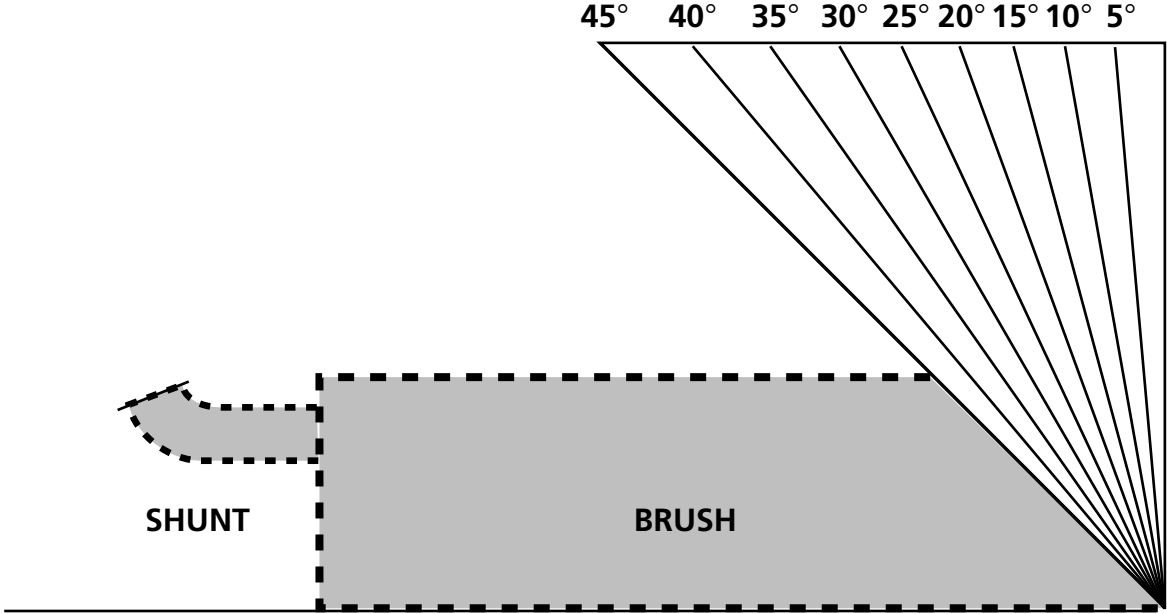

Figure 19. Terminal Openings

Example: 9S45 = 9/32 Slotted Terminal Bent 45°

# Bevel Chart



# Radius Chart

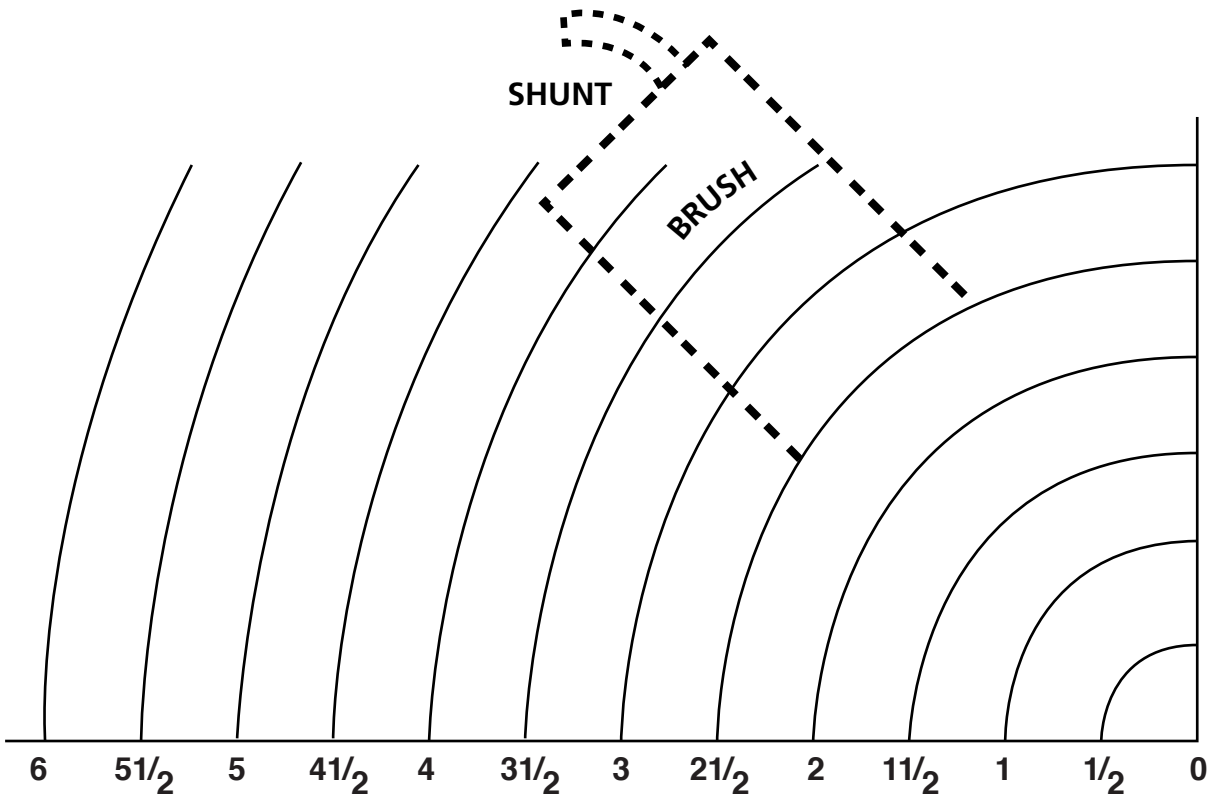

Note: Slip ring brushes, where the thickness is greater than or equal to the width, should always be pre-radiused to match the slip ring contour. If no radius is specified, A 6" radius will be supplied.

**SYMPTOMS**

M	THREADING AND GROOVING OF COMMUTATOR OR SLIP RING
L	EXCESSIVE COMMUTATOR WEAR - SURFACE BLACKENED
K	COPPER DRAGGING
J	EXCESSIVE COMMUTATOR OR SLIP RING WEAR - BRIGHT SURFACE / FILM STRIPPING
I	UNEQUAL BRUSH WEAR
H	RAPID BRUSH WEAR - WHILE COMMUTATION GOOD
G	SHUNTS BURNED OUT OR DISCOLORED
F	BRUSHES AND BRUSH HOLDERS TOO HOT
E	COMMUTATOR - SLIP RING - TOO HOT
D	SPARKING VICIOUS AND TRAILING AROUND COMMUTATOR
C	EXCESSIVE BRUSH VIBRATION
B	SPARKING AT THE ENTERING EDGE
A	SPARKING AT THE LEAVING EDGE

PROBABLE CAUSE OF TROUBLE	A	B	C	D	E	F	G	H	I	J	K	L	M
INTERPOLE FIELD TOO STRONG		•	•				•						
INTERPOLE FIELD TOO WEAK	•		•				•				•		
INTERPOLE AIR GAP TOO SMALL		•	•				•						
INTERPOLE AIR GAP TOO LARGE	•		•				•				•		
AIR GAPS UNEVEN (BEARINGS WORN)	•	•							•				
OVERLOAD OF MACHINE	•				•	•	•		•	•			
VIBRATION FROM EXTERNAL CAUSES, i.e., PRIME MOVER: NEARBY FORGE HAMMER, etc.	•								•		•		
VIBRATION FROM INTERNAL CAUSES, i.e., OUT OF BALANCE, POOR ALIGNMENT, etc.	•								•		•		
OIL AND DIRT ON COMMUTATOR OR SLIP RING	•							•	•				•
RESISTANCE BETWEEN BRUSHES AND BRUSH ARMS NOT UNIFORM						•	•		•				
GRAINS OF ABRASIVE IN THE BRUSH CONTACT FACE									•	•			•
FAULTS IN ARMATURE WINDING OR EQUALIZER CONNECTIONS	•			•		•							
HIGH MICA	•		•	•								•	
COMMUTATOR OR SLIP RING ECCENTRIC	•							•				•	
COMMUTATOR RISER CONNECTIONS OPEN CIRCUITED	•	•	•	•									
HIGH OR LOW COMMUTATOR SEGMENTS	•		•	•								•	
COMMUTATOR LOOSE	•		•	•								•	
FLATS ON COMMUTATOR OR SLIP RING	•		•	•								•	
BRUSH PRESSURE TOO LOW	•				•	•	•	•	•	•	•	•	•
BRUSH PRESSURE TOO HIGH					•	•		•		•	•		•

NOTE: The time factor is important. If consulting a National Application Engineer, state whether the trouble is new, or of long standing.

**SYMPTOMS**

- M THREADING AND GROOVING OF COMMUTATOR OR SLIP RING
- L EXCESSIVE COMMUTATOR WEAR - SURFACE BLACKENED
- K COPPER DRAGGING
- J EXCESSIVE COMMUTATOR OR SLIP RING WEAR - BRIGHT SURFACE / FILM STRIPPING
- I UNEQUAL BRUSH WEAR
- H RAPID BRUSH WEAR - WHILE COMMUTATION GOOD
- G SHUNTS BURNT OUT OR DISCOLOURED
- F BRUSHES AND BRUSH HOLDERS TOO HOT
- E COMMUTATOR - SLIP RING - TOO HOT
- D SPARKING VICIOUS AND TRAILING AROUND COMMUTATOR
- C EXCESSIVE BRUSH VIBRATION
- B SPARKING AT THE ENTERING EDGE
- A SPARKING AT THE LEAVING EDGE

PROBABLE CAUSE OF TROUBLE	A	B	C	D	E	F	G	H	I	J	K	L	M
SPRING PRESSURE UNEQUAL	•					•	•		•				
BRUSH GRADE UNSUITABLE FOR MACHINE AND DUTY	•			•	•	•		•	•	•	•	•	•
BRUSH ARC OF CONTACT EXCESSIVE	•	•	•										
BRUSH ARC OF CONTACT INSUFFICIENT	•	•	•										
BRUSH SHUNT CONNECTION FAULTY							•		•				
BRUSH SHUNT TOO SHORT OR TOO STIFF	•				•		•		•				
IMPERFECT BRUSH BEDDING	•	•			•				•				
RADIAL BRUSH HOLDERS MOUNTED AT SMALL REACTION ANGLE	•				•				•		•		
BRUSH STICKING OR SLUGGISH IN BRUSH HOLDER	•				•		•	•	•			•	
BRUSHES TOO LOOSE IN BRUSH HOLDER (HOLDERS WORN)	•					•			•				
TERMINAL CONNECTIONS LOOSE OR DIRTY					•	•	•		•				
BRUSH HOLDER MOUNTED TOO FAR FROM COMMUTATOR OR SLIP RING	•								•				
INCORRECT BRUSH POSITION	•	•	•									•	
UNEQUAL BRUSH HOLDER SPACING OR ALIGNMENT	•	•	•	•			•		•				
HUMIDITY OF ATMOSPHERE LOW								•		•			
HUMIDITY OF ATMOSPHERE EXCESSIVE											•		•
DUSTY ATMOSPHERE								•		•			•
GAS OR ACID FUMES IN ATMOSPHERE	•						•	•					•
LONG PERIODS AT LOW OR STEADY LOADS											•		•
SILICONE CONTAMINATION								•					
FUMES FROM OILS WITH HIGH PRESSURE ADDITIVES											•		

**SYMPTOMS**

											SYMPTOMS	
											WEAR OF SLIP RING ON ONE POLARITY	N
											COPPER PICKING IN BRUSH FACE	O
											BRUSH CHATTER	P
											COMMUTATOR SURFACE STREAKY	Q
											COMMUTATOR HAS UNSYMMETRICAL BURN MARKS	R
											COMMUTATOR HAS SYMMETRICAL BURN MARKS	S
											COMMUTATOR HAS WAVY PATTERN	T
											GHOST MARKS ON STEEL SLIP RINGS	U
											PITTED CONTACT SURFACE OF BRUSH	V
											CHIPPING OF BRUSH EDGES OR BRUSH BREAKAGE	W
											FAILURE TO DEVELOP A PROTECTIVE SKIN	X
N	O	P	Q	R	S	T	U	V	W	X	REMEDY	
	•				•			•			WEAKEN INTERPOLE FIELDS BY DIVERTING OR BY INCREASING GAP	
	•				•			•			STRENGTHEN INTERPOLE FIELDS BY REDUCING AIR GAP	
	•				•			•			ENLARGE AIR GAP TO DECREASE EFFECTIVE INTERPOLE FLUX	
	•				•			•			REDUCE AIR GAP TO INCREASE EFFECTIVE INTERPOLE FLUX	
	•				•			•			RENEW BEARINGS AND REALIGN MACHINE	
	•					•		•			REDUCE AND LIMIT LOAD ON MACHINE	
•	•	•			•	•	•	•	•	•	LOCATE AND REMOVE CAUSE OF VIBRATION	
•	•				•	•	•	•		•	BALANCE ARMATURE AND CHECK FOR BEARING WEAR	
•								•			REVERSE THE POLARITY OF RINGS PERIODICALLY	
			•	•						•	CLEAN COMMUTATOR OR SLIP RING	
					•			•			CLEAN AND TIGHTEN THE CONNECTIONS	
										•	REBED AND CLEAN THE BRUSH FACE	
				•	•			•			LOCATE AND CURE FAULT OR CONSULT MANUFACTURER	
	•	•		•				•	•	•	RECESS MICA, OR USE MORE ABRASIVE BRUSH	
•	•		•	•		•		•			TURN OR REGRIND PREFERABLY AT NEAR RATED SPEED	
					•						REPAIR RISER AND EQUALIZER CONNECTION	
		•		•				•			TIGHTEN COMMUTATOR, TURN, OR REGRIND	
	•	•	•	•		•			•		REBUILD OR REPLACE COMMUTATOR IF NECESSARY	
	•	•						•	•		LOCATE AND REMOVE CAUSE OF FLATTING, TURN OR REGRIND	
•	•	•	•	•	•		•	•	•	•	ADJUST BRUSH PRESSURE ( FOR SPRING FORCE) TO THAT RECOMMENDED FOR THE MACHINE	

**SYMPTOMS**

											WEAR OF SLIP RING ON ONE POLARITY	N
											COPPER PICKING IN BRUSH FACE	O
											BRUSH CHATTER	P
											COMMUTATOR SURFACE STREAKY	Q
											COMMUTATOR HAS UNSYMMETRICAL BURN MARKS	R
											COMMUTATOR HAS SYMMETRICAL BURN MARKS	S
											COMMUTATOR HAS WAVY PATTERN	T
											GHOST MARKS ON STEEL SLIP RINGS	U
											PITTED CONTACT SURFACE OF BRUSH	V
											CHIPPING OF BRUSH EDGES OR BRUSH BREAKAGE	W
											FAILURE TO DEVELOP A PROTECTIVE SKIN	X
N	O	P	Q	R	S	T	U	V	W	X	REMEDY	
•		•			•			•	•	•	SELECT ONE OF OUR ALTERNATIVE GRADES OR ASK FOR OUR RECOMMENDATION	
	•				•						APPLY A SUITABLE CIRCUMFERENTIAL STAGGER, PREFERABLY CONSULT MANUFACTURER	
											FIT A NEW BRUSH WITH A SOUND FLEXIBLE CONNECTION	
					•						USE BRUSHES WITH FLEXIBLE OF CORRECT LENGTH AND FLEXIBILITY	
			•							•	BED BRUSHES BY OUR RECOMMENDED METHOD	
•		•		•	•			•		•	ADJUST HOLDERS TO A RADIAL POSITION, AND CORRECT DISTANCE FROM COMMUTATORS SEE * BELOW	
•		•		•	•			•			REVERSE HOLDERS OR DIRECTION OF ROTATION	
	•		•	•		•			•		CHECK THAT BRUSH SIZE IS CORRECT, CLEAN BRUSHES AND HOLDERS, REMOVE ANY BURRS	
		•			•			•		•	IF HOLDERS WORN, REPLACE WITH NEW ONES, ORDER BRUSHES OF CORRECT DIMENSIONS	
		•									CLEAN TERMINAL AND TERMINAL BLOCK, TIGHTEN SCREWS	
•		•	•	•	•			•		•	* ADJUST HOLDER TO BE 3/32 in. OR 2m.m. FROM COMMUTATOR	
	•				•		•		•		ADJUST HOLDERS TO CORRECT POSITION	
	•				•				•		CORRECT SPACING AND ALIGNMENT OF HOLDERS	
		•						•		•	HUMIDIFY THE COOLING AIR OR DRAW AIR FROM NORMAL HUMIDITY SOURCE	
			•				•				ENCLOSE MACHINE OR DRAW COOLING AIR FROM NORMAL HUMIDITY SOURCE	
										•	REMOVE CAUSE IF POSSIBLE OR INSTALL FILTER	
			•	•			•		•	•	ARRANGE CLEAN AIR COOLING	
	•	•						•		•	CHANGE BRUSH GRADE, ASK FOR OUR RECOMMENDATION	

# Calculating Brush Current Density

The proper Brush Current Density or APSI (amps per square inch) depends on the brush grade. Each grade has a range of current density where minimum commutator wear and optimum brush life will result.

To calculate the current density you need to know or measure: the operating current in amps, the number of brushes and the brush thickness and width. Brush T x W = the cross sectional area. Brushes that contact the commutator at an angle do have more contact area than the product of their T x W, but it is usually not a significant difference so the easier to calculate cross sectional area is used.

Inches

$$\text{Current Density (DC Motor)} = \frac{\text{Amps}}{1/2 \# \text{ BR} \times \text{T} \times \text{W}}$$

Metric

$$\text{Current Density (DC Motor)} = \frac{\text{Amps} \times 100}{1/2 \# \text{ BR} \times \text{T} \times \text{W}}$$

$$\text{Current Density (Slip Ring)} = \frac{\text{Amps}}{\# \text{ BR} \times \text{T} \times \text{W}}$$

$$\text{Current Density (Slip Ring)} = \frac{\text{Amps} \times 100}{\# \text{ BR} \times \text{T} \times \text{W}}$$

Example: 125HP DC Motor rated  
500 Volts, 201 amps  
and has 8 brushes

$$\text{Current Density} = \frac{201}{1/2 (8) \times .625 \times 1.250} = 64.3 \text{ APSI}$$

Example: 100KW DC Motor  
rated 500 Volts,  
217 amps and has

$$\text{Current Density} = \frac{217 \times 100}{1/2 (8) \times 16 \times 32} = 10.5 \text{ am ps/cm}^2$$

**Note: Customer Service or Application Engineering can help with grade selection as the operating APSI are calculated.**

## Metric and Decimal Equivalents

Metric	
mm	inches
1	0.03937
4	0.157
8	0.315
10	0.394
12	0.472
12.5	0.492
16	0.630
20	0.787
25	0.984
32	1.260
40	1.575
50	1.969

Fraction	Decimal inches
1/16	.0625
1/8	.125
3/16	.1875
1/4	.250
5/16	.3125
3/8	.375
7/16	.4375
1/2	.500
9/16	.5625
5/8	.625
11/16	.6875
3/4	.750
13/16	.8125
7/8	.875
15/16	.9375
1	1.000

# Brush Specification Form

Company	
Location	
Application / Service	
Motor Manufacturer	
Model #	
Serial # or ID #	
Type or Frame	

HP=_____ (kw)	Nameplate Rating	Operating Value
RPM		
Volts		
Amps		

Brush # now in use	
Brush Thickness	
Brush Width	
Brush Lg. New/Worn?	
#Br. per arm or ring	Total=
Grade in use / wanted	/

Style: Single  Q=Tamped  Clip   
 Dual  R=Riveted  Pad   
 Triple  None

Terminal	
Bevels Top / Bottom	/
Bottom Radius	
Comm/Slip Ring Dia.	
Slip Ring Qty & Matl.	

Shunts: Qty. \_\_\_\_\_ Plain   
 Length: \_\_\_\_\_ Plated   
 Location: \_\_\_\_\_ Insul.

Brush Orientation: Radial  Stub  Trail   
 Metric Dimensions: Yes  No

Style= _____ (see page 1-5)	Pad Style= _____ (see page 9)
-----------------------------	-------------------------------

Sketch or trace brush for clarification of style or list special requirements in this space.

**MorganAM&T**

 **NATIONAL**<sup>®</sup>

251 Forrester Drive  
Greenville, SC 29607-5328 USA  
1.800.543.6322  
1.864.458.7777  
[www.morganamt.com](http://www.morganamt.com)

