

# 3 Unraveling the Commutation Mystery

MorganAM&T™



## Introduction

When direct current motors and generators are manufactured, they are tested and adjusted at the factory to provide desired output characteristics and optimum commutation. Once these machines are put in service, the original adjustment of the machine may be disturbed when the components are changed or when work is done on the motors or generators. This can lead to excessive sparking at the brushes and possibly reduce brush life and increase commutator wear. In order to restore these machines to good operating condition, it may be necessary to adjust them in the field.

## DC Machine Basics

Before discussing the adjustment of DC machines, it is important to understand how DC generators produce voltage and current, and how various machine components assist in the commutation process.

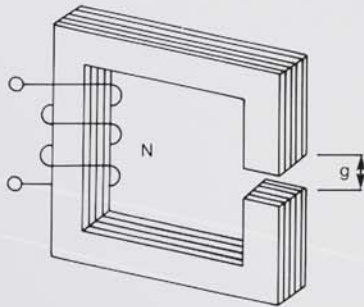

$N$  = Number Of Turns  
 $g$  = Air Gap

**Figure 1**

A DC motor or generator is constructed of a magnetic circuit consisting of iron or steel parts and an air gap ( $g$ ) (Figure 1). The air gap allows for movement between the rotating and stationary parts of the machine. Inside the machine are various windings made of electrical conductors that wrap around the iron parts of the motor or generator. These windings have some number of turns ( $N$ ). If a DC voltage ( $e$ ) is applied across a winding, a current ( $i$ ) will flow through the winding, and this current will be determined by the voltage ( $e$ ) and the resistance of the winding according to Ohm's Law (Figure 2). The current flowing through this winding will magnetize the iron parts of the core and cause a magnetic flux ( $\phi$ ) to flow through the iron parts and across the air gap. The amount of flux is proportional to the product of the number of turns ( $N$ ) times the current ( $i$ ).

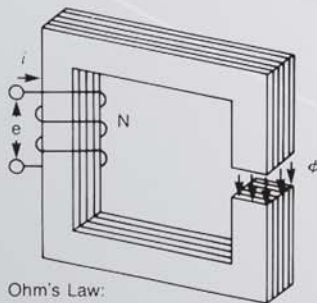

Ohm's Law:  
 $i = \frac{e}{R}$

$\phi \propto N \times i$   
**Figure 2**

The relationship between the product of  $N$  times  $I$  (ampere-turns) and flux is not linear (Figure 3). At low flux levels, the flux is proportional to the ampere-turns. The primary resistance to the flow of flux at these flux levels is the air gap in the machine. At higher flux levels it becomes increasingly difficult to force more flux through the iron parts of the machine. This is called "saturation" of the iron. Here it takes a large increase of ampere-turns to get only a small increase in flux. The relationship for flux and ampere-turns for a DC machine is shown by the saturation curve (Figure 3).

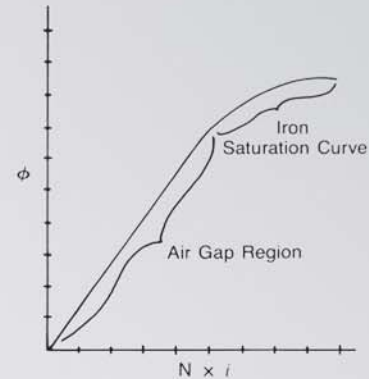

**Figure 3**

If the current in a winding of a DC machine is established and the flow of flux is established and something happens that causes a change in the flux or current in the winding, a voltage will be produced at the terminals of the winding (Figure 4). The voltage is proportional to the number of turns times the rate of change of flux ( $d\phi/dt$ ). Notice the negative sign which indicates this voltage is produced in such a way as to oppose the change in flux. Another way of writing this equation is using a property called "inductance" ( $L$ ). A voltage will be produced that is proportional to the inductance times the rate of change of current ( $di/dt$ ). Again the negative sign indicates that the voltage opposes the change in current; that is, it attempts to keep the current flowing in the same direction.

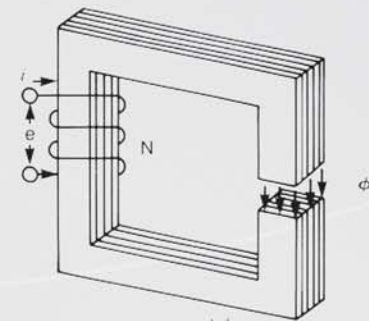

$$e = -N \frac{d\phi}{dt}$$

$$e = -L \frac{di}{dt}$$

**Figure 4**

If a conductor is passed through the magnetic flux in the air gap with a velocity ( $v$ ), a voltage will be produced at the ends of the conductor (Figure 5). This voltage is called an E.M.F. or electromotive force. The voltage is proportional to the flux density (flux per unit area) times the length of the conductor ( $l$ ) in the air gap times the velocity at which it is moved through the air gap. The voltage will increase with higher flux densities, longer lengths of conductors or movement at a higher velocity.

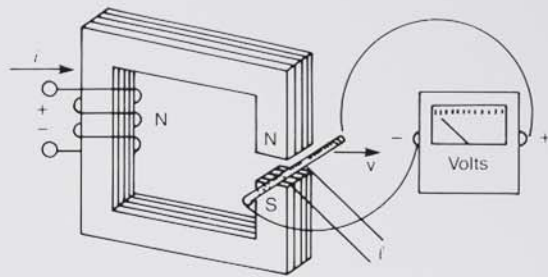

Volts = E.M.F. =  $B \times l \times v$

where:

$B$  = Flux Density ( $\phi$ /Area)

$l$  = Length of Conductor

$v$  = Velocity of Conductor

Figure 5

If a circuit is completed so that current can flow through the conductor, it will take some force (F) to pull the conductor through the air gap (Figure 6).

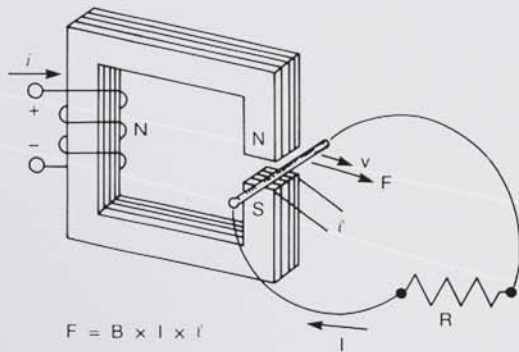

$F = B \times l \times i$

where:

$B$  = Flux Density ( $\phi$ /Area)

$i$  = Current

$l$  = Length of Conductor

Figure 6

The amount of force it takes is equal to the flux density times the current in the conductor times the length of the conductor in the air gap. Higher flux densities, more current in the conductor or a longer length of conductor will increase the force required to pull that conductor through the air gap. Therefore, in a direct current generator, an output voltage will be produced that is proportional to the flux density (B) times the length (l) times the velocity of the conductor (v).

$V = B \times l \times v$

Since the length of the conductor is determined when the machine is designed and the velocity is related to the RPM of the generator which is constant, we see that the output voltage of a DC generator is proportional to the flux density (B) which is related to the generator field current by the saturation curve. The output voltage of a direct current generator is controlled by adjusting its field current.

Direct current motors work by the same laws as direct current generators (Figure 7). A voltage will be produced that is equal to the flux density times the length times the velocity. Since the length is predetermined and the velocity is related to the RPM, we see that the voltage is proportional to the flux density (B) times the RPM. If this equation is rearranged to solve for the RPM, we find that RPM is proportional to the voltage applied to the motor divided by the flux. Since

the flux density is determined by the field current, we see the RPM is proportional to the voltage divided by the field current. This means that the higher the voltage applied to the motor, the faster it will rotate. Also, if the motor field current is high, the motor will run slower. If the motor field current is low, the motor will run faster. On excavators, there is often a strong and weak field setting for the DC motors. This allows the motors to run faster for a given voltage in the weak field setting. An example of this would be paying out the drag motion on a dragline.

Speed  $V = B \times l \times v$

$V \propto B \times \text{RPM}$

$\text{RPM} \propto \frac{\text{Volts}}{B} \propto \frac{\text{Volts}}{\text{Field}}$

Torque

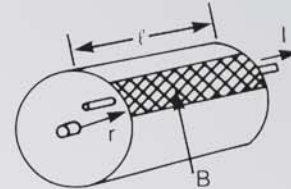

Force  $\propto B \times l \times i$

Torque = Force  $\times$  Radius

Torque  $\propto B \times l$

Figure 7

If we look at the illustration on Figure 7, we see an armature with a core length (l) and a conductor passing through this armature at radius (R) from the center line of the shaft. Flux density (B) enters the armature in the cross-hatched area. If current flows through the conductor in this armature and the armature rotates so as to pass the conductor through the magnetic flux, a force will be produced on this conductor that is proportional to the flux density times the current times the length of the armature iron. Torque is equal to force times radius, and since the length of the armature is predetermined at the time of machine design, we can see that for a given machine, the torque is proportional to the flux density times the current in the armature. As the current in the DC motor increases, its output torque increases. Also, if the flux density is high, such as in the strong field setting, the torque will be high. If the flux density is low, such as when the field is weakened, the torque will be low. Looking at the speed and torque equations, we see that high field flux produces high torque and low speed. Low field flux produces low torque and high speed.

The ability to control the speed and torque of these motors has made DC drives the choice for powering industry for many years.

The next important consideration in DC Machinery is the commutation process. Commutation is the reversal of current in the armature windings of a DC machine. Figure 8 shows an example of a part of the DC machine showing a North and South main pole. As the armature passes under the main poles, the current in individual conductors reverses. If we look at this graphically, we see that we have positive current underneath the North pole and negative current underneath the South pole. During the time that the armature conductors pass between the North and South pole, the current must reverse. This change in current is known as  $\Delta i$  and this occurs during a time period  $\Delta t$ . Recall that if we have a change in current in a winding of a motor, there will be a voltage produced (V) that is equal to minus the inductance times the rate of change in current  $di/dt$ . This

can be represented as inductance times  $\Delta I$  divided by  $\Delta t$ . This voltage that is produced is called the "reactance voltage". Its polarity is such that it would try to keep armature current flowing in the same direction, which is undesirable. Ideal or linear commutation is represented in Figure 8. Actual current reversal will be somewhat different.

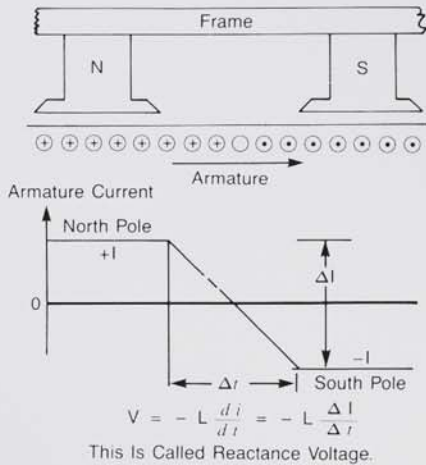

**Figure 8**

In order to help the current reverse, an additional component is added to DC machines. This part is called a "commutating pole" or "interpole". It fits between the main poles and produces a flux that cuts the armature conductor (Figure 9).

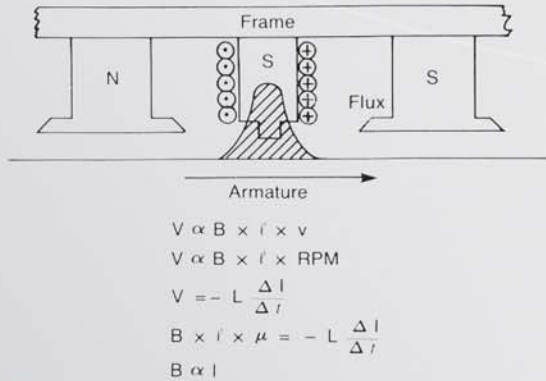
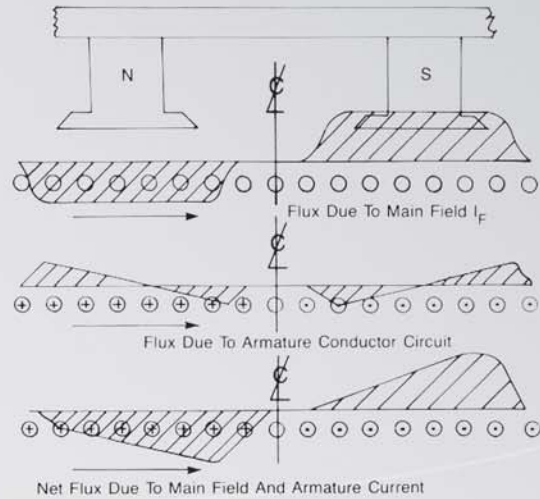

**Figure 9**

A voltage will be produced in the armature conductors that is proportional to the flux density times the length of the conductors times the velocity, which is the same as saying the voltage is proportional to the flux density times the length of the conductors times the RPM. We would like this voltage to be exactly equal to the reactance voltage, which is equal to minus L times  $\Delta I/\Delta t$ . If we set these voltages equal and realize that the length of the conductors is determined by the machine designer, the velocity is constant for a generator, the inductance is fixed by the machine design, and the change in time is determined by the speed of the machine, we see that we would like to have a flux density produced by the commutating pole that is proportional to armature current. This is done by connecting the windings on the commutating pole in series with the armature. The commutating pole magnetic circuit should not be saturated so that flux is always proportional to ampere-turns.

If we look at the flux distribution underneath the main poles (Figure 10), we see that there is a uniform distribution of flux when the main field is excited. If we look at the distribution

of flux, if there is current in the armature but no excitation of the main fields, we see a flux distribution as shown in the center of Figure 10. If we have both main field excitation and current in the armature, the fluxes combine as shown at the bottom of Figure 10. The flow of current in the armature distorts the main pole flux and causes the flux density to be high at one pole tip of each pole. It also distorts the flux so that it may not be zero near the center line between the main poles. This tends to sustain armature current in the same direction, which is undesirable. The effect of armature current on the flux in the air gap is called "armature reaction".



**Figure 10**

In order to cancel the effect of armature reaction, one additional winding is placed in large DC machines. This winding is called "pole face winding" (Figure 11). The pole face winding consists of large conductors placed through the face of the main pole pieces. They are connected in a manner that opposes the flux from current in the armature conductors. The pole face winding cancels the effect of armature reaction, reduces the bar to bar voltage at the commutator bars and improves some output characteristics of the machine, notably speed stability in DC motors. The pole face winding is connected in series with the armature.

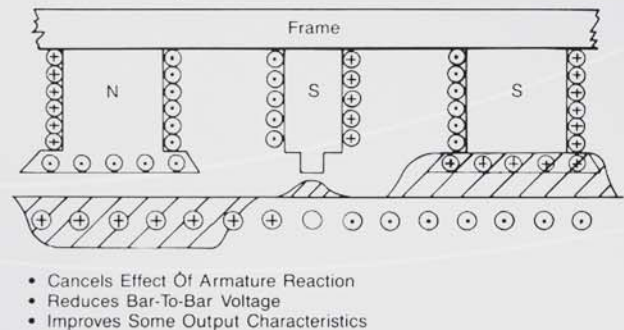

**Figure 11**

In order for a machine to commute properly, it is necessary to adjust or "fine tune" the amount of flux from the commutating fields. Since the amount of flux is proportional to the number of turns times the current, and the number of turns and current are predetermined by the machine design and load, some method must be provided to adjust the amount of flux. This can be done by changing the air gap. There are two air gaps in the magnetic circuit for the commutating fields (Figure 12).

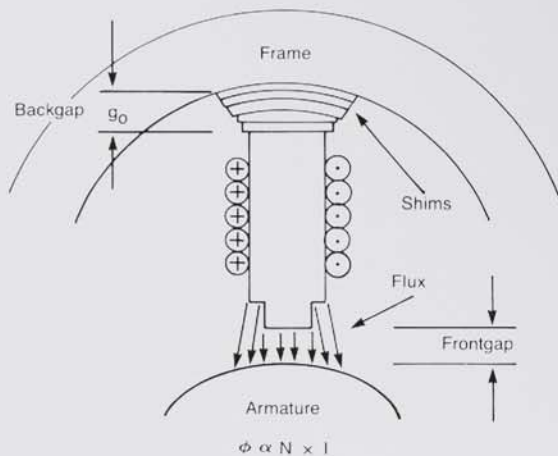

Figure 12

One air gap is between the commutating pole tip and the armature. This gap is called the “front gap”. Increasing the front gap reduces the amount of flux for given ampere-turns in the commutating field winding. It also changes the distribution of flux over the armature surface. Since it is desirable to have a certain flux distribution, large changes in the “front gap” are not recommended. A second “air gap” is provided between the back of the commutating pole and the machine frame. This gap is called the “back gap”. It consists of non-magnetic shims, usually aluminum or brass. By adjusting the quantity of non-magnetic and magnetic shims in this area, the amount of flux can be adjusted. The order of the shims is important as well as the quantity of magnetic and non-magnetic shims. The correct order for GE machines is thin steel shims next to the frame, thin aluminum shims, thick aluminum shims and thick steel shims next to the commutating pole.\*

\*Other motor manufacturers may use a different shim arrangement.

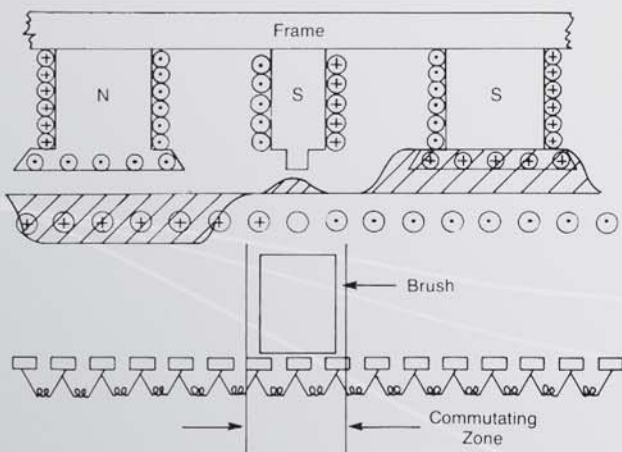

Figure 13

Another adjustment that can be made in DC motors and generators is the position of the brushes on the commutator surface. The brush arms are connected to a large ring which can be moved on larger machines. When properly positioned, the brushes will contact commutator segments that are connected to armature coils that are passing through the commutating zone where armature current is reversing (Figure 13). Since the relationship between the position of

armature conductors and commutator bars varies slightly from one armature to the next, it is important to check brush position when a new armature is installed.

If brush position or the amount of flux from the commutating poles is incorrect, the current in the armature windings will not reverse properly and sparking will result at the brushes causing reduced brush life and deteriorating commutator surface conditions.

The brush position and commutating field strength are adjusted at the factory by a method called the “black band” method of commutation adjustment. This method requires large and specialized equipment that is not practical for use in the field. Other methods of checking machine adjustment are necessary for use in the field.

### Machine Adjustment in the Field

Increased sparking levels at the brushes, rapid brush wear or burning or etching of commutator bars are signs that commutation is not occurring properly in a DC motor or generator. If this happens, it is necessary to determine why the machine is not working properly. Also, if any major component of the machine is changed or the machine has been disassembled, it may be necessary to check machine adjustment.

**WARNING:** Working around rotating electrical machinery can cause serious or fatal injury due to electrical shock hazards or contact with rotating parts. Contact the original equipment manufacturer’s service engineers for performing adjustments on electrical motors and generators. These people have the necessary training and information available for properly adjusting DC machines.

Before adjusting a motor or generator, it is important to determine that the components are of good integrity and that the machine is properly assembled. There are two methods that can be used to check the integrity of main coils and commutating coils. The first of these methods is called the “DC drop” method. To measure DC drops, a steady state current is passed through the main coil or commutating coil windings and the voltage drop at individual coils is measured. If there are shorted turns in an individual coil, its DC voltage drop will be low. DC drops are easy to measure and can usually be done without disconnecting the machine. The DC drop method is somewhat limited in that it may not show shorted turns if the short is minor or only a few turns are shorted.

A second method of checking for shorted turns is the “AC drop” method. To perform AC drop tests on main field coils, two or more coils are connected in series and an AC voltage is applied to the coils. Since these coils have a very high inductance that will limit the current, it is possible to connect them directly across a 120 volt AC line. The voltage is measured at each coil using a standard voltmeter. If there are shorted turns in a coil, the shorted turns will act as a shorted secondary of a transformer and will reduce the impedance of the coil. The coil with shorted turns will have a lower voltage drop than the good coils.

Commutating field coils have a much lower impedance and so need a high current/low voltage source for AC excitation. It has been found that a standard pistol-grip soldering gun can be used as a current source for measuring AC drops

on commutating coils. Two or more coils are connected in series for these measurements.

The AC voltages on main field and commutating field coils should agree within 15%. The armature may be in place or removed when making these measurements, but the frame must not be split or erroneous data will result.

Another important factor for good commutation is uniform brush spacing around the commutator. On pedestal type machines, individual brush arms are adjustable. Using a paper tape, such as an adding machine tape, it is possible to measure the space between individual brush boxes around the commutator surface. All brush studs should be spaced within  $3/64$ " (0.047") or 12mm. Brush boxes should be spaced .070" to .080" or 1.8mm to 2mm above the commutator surface.

Also, uniform air gaps between the armature core and the poles is important. On pedestal machines, the frames are independently adjustable from the bearings (i.e. armature). It is possible to have non-uniform or tapered air gaps. Air gaps should be equal within .007" or 0.18mm for the main poles or the commutating poles.

Note: The main poles will have a different air gap than the commutating poles.

The spacing between main and commutating pole tips is also important. If this spacing varies more than  $1/8$ " (0.125") or 3.2mm, the commutating field flux will not pass through the proper armature conductors.

The commutator surface should have no more than .003" or 0.08mm run out and no more than .0002" or 6 microns variation between two adjacent commutator bars. An easy way to check this is by using a device that consists of a linear voltage transducer with a mating power supply and a strip chart recorder.

Finally, it is import that the electrical connections in all the windings of the machine be tight and corrosion free and vibration should be within the limits shown in the motor or generator instruction book.

The first adjustment of machines that is made in the field is the brush position. This is done by a technique called the "pencil volt neutral" test. A special template is made that fits around the brush on one brush path. The template has a series of small holes drilled through it and by measuring the voltage from the commutator surface to the brush stud through these holes, the proper brush position can be determined. The machine is operated at approximately 100 volts no-load for this test. There are a number of alternate static or operating tests that can be used to set brush position.

Once proper brush position has been established, the next check is to determine if the proper flux is being produced by the commutating fields. This is done by a method called "lead-trail voltage". The voltage is measured at the leading and trailing edge of the brush with the generator operating at full load and low voltage. This can be done by using the template and pencil probe or by using a special insulated brush.

### Carbon Brushes

Carbon brushes provide the electrical contact between the stationary and rotating parts of DC machines. The brushes carry load current into the rotating parts and aid in the commutation process. By controlling the ingredients that go into the base carbon of the brush, certain properties of the brush can be controlled. The base carbons are manufactured in various grades which we call the "electrographitic family" of brushes. This type of brush is used in most DC machines. They get their name from the manufacturing processes where the carbon is graphitized in high temperature electric furnaces. These grades are generically shown as A through E on Figure 14. The strength of the base carbon is increasing as we move from grade A through E. Generally the lower strength carbons have higher resistance.

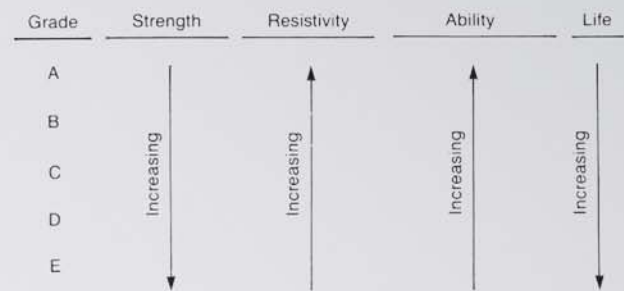

Figure 14

The commutating ability of the brush is a combination of the lower strength or modulus of the brush and the lower density which allows it to ride the commutator better along with the higher resistance which reduces the circulating current in the brush face. In general, life increases as the strength increases due to the ability of the brush to resist mechanical wear. However, the high strength brushes do not have the commutating ability of the lower strength materials, and if a brush is selected that does not have sufficient commutating ability for a particular machine, its life will actually be reduced due to electrical wear.

After the base carbon is manufactured, it is usually treated with some organic or inorganic materials. Very few modern machines use brushes that are not treated. The treatments added to the brush improve its characteristics as follows:

- Improve Brush Life
- Improve Filming
- Provide Low Humidity Protection
- Allow High Temperature Operation
- Prevent Copper Drag in High Humidity Operation
- Allow Operation in Contaminated Atmospheres
- Minimize Commutator Wear
- Reduce Friction

Specific treatments are used in specific applications, and the development of new treatments is an ongoing process.

Figure 15 shows how brush material properties can affect circulating currents in the brush face. There is always some uncompensated reactance voltage  $V_R$  in the armature coils. This voltage will cause current to flow through the armature coil and through the brush face. An equation is shown for the voltage drops around this circuit. The first voltage drop is the circulating current times the resistance of the armature conductor. There is a voltage drop as the current passes from the commutator segment to the brush, which is

called the "contact drop". It is shown as  $V_{CD}$ . Next, we have a voltage drop as the current flows through the brush faces, shown as  $i$  times  $R_B$ . And finally, there is one more voltage drop as the current passes back from the brush into the commutator segment, shown as  $V_{CD}$ . When this equation is solved for current, we see that the term for the resistance of the brush is in the denominator. If higher resistivity brushes are used, the denominator becomes larger and the circulating current is reduced. Also, higher resistance brushes have a higher contact drop. This increases the term  $V_{CD}$  which is subtracted from  $V_R$  in the numerator. This also tends to reduce the circulating current in the brush face. Therefore, higher resistivity brushes are used for difficult-to-commutate machines. The resistance of the brush material cannot be increased indiscriminately. The load current must also pass through the carbon, and higher resistance materials can cause higher losses and higher brush temperatures.

**Summary**

A number of factors can affect the commutation of DC motors and generators. Some of these are related to the DC machine design, symmetry, or adjustment. Some are related to the brush design and materials. A properly assembled and adjusted machine, using a suitable brush, should have relatively low levels of sparking and good commutator and brush life.

Richard D. Hall  
Senior Design and Application Engineer.

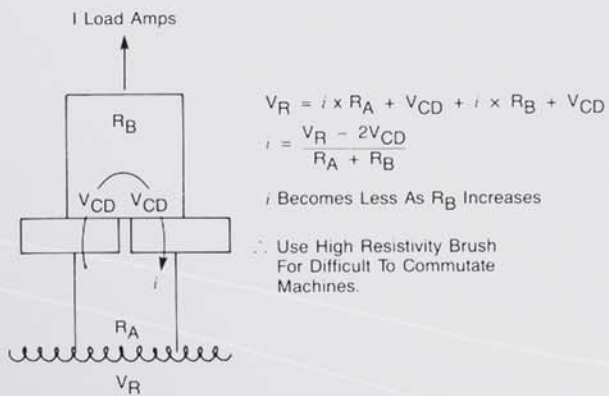

**Figure 15**

Another way to limit the circulating current in the brush face without increasing the resistivity of the carbon, is to use a multiwafer brush construction. Figure 16 shows the voltage drops through a brush of this type. An extra term is added for the voltage drop between the wafers shown as  $i$  times  $R_W$ . When the equation is solved for current, this term is in the denominator. Using a split brush increases the resistance around the loop and reduces the circulating current in the brush face. Split brushes will also follow slight imperfections in the commutator surface more easily.

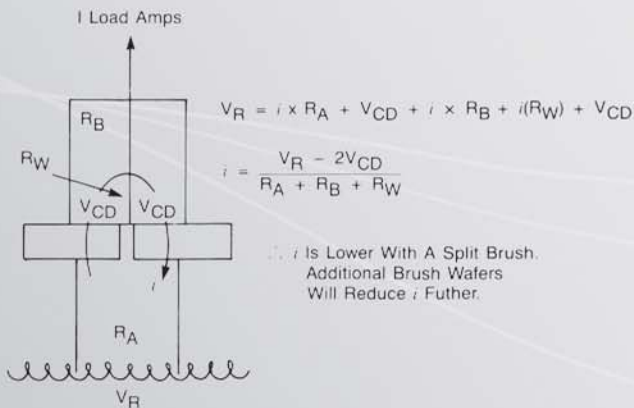

**Figure 16**

**MorganAM&T**<sup>™</sup>

 **NATIONAL**

251 Forrester Drive  
Greenville, SC 29607-5328 USA  
1.800.543.6322  
1.864.458.7777  
[www.morganamt.com](http://www.morganamt.com)

ISO 9001

